

Overview

The CAP-HT-100-AP Infrared and Gold Cup Inspection Windows are expertly crafted for high-temperature environments, capable of withstanding surface temperatures as high as 1832°F (1000°C). Perfectly suited for furnace applications, they feature a rugged sapphire crystal lens and a port hole. These windows are compatible with any SWIR and MWIR thermography camera and support Gold Cup inspection, enabling precise monitoring in the shortwave and midwave IR spectrum and accurate temperature measurements. The design ensures equipment remains sealed during inspections, protecting against heat exposure and prioritizing the safety of both maintenance personnel and the machinery involved.

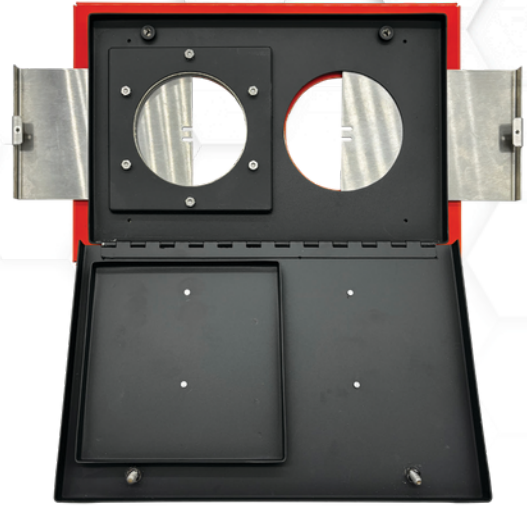

Key Features



Extreme High-Temperature Applications

Engineered for extremely high-temperature applications, withstanding surface temperatures up to 1832°F (1000°C).



Durable and Rugged

Constructed with a 100% stainless steel high temperature powder coated body and sapphire crystal optic.



Closed Furnace / Oven Inspections

Designed to ensure equipment stays enclosed during the inspection to prevent exposure to high temperatures.



Extreme Temperature Optics

Our exclusive sapphire optic system enables personnel to perform safe and accurate visual, SWIR, MWIR, and UV inspections.



Stainless Steel Dust-Free Covers

Sliding stainless steel dust covers protect the inspection window from dust and debris buildup, ensuring a clear view and maintaining optimal performance in harsh environments.



Limited Lifetime Warranty

The IRISS limited lifetime warranty provides unparalleled protection against manufacturer defects.

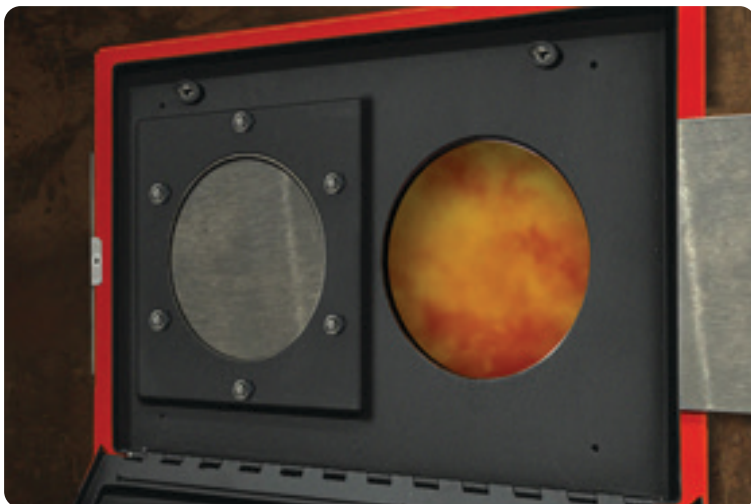

Specifications

Model	CAP-HT-100-AP
General Specifications	
Overall Height	21.33 cm (8.399 in)
Overall Width	32.43 cm (12.766 in)
Operating Temperature	Surface Temperature -40°C (-40°F) to 1832°F (1000°C)
Body Material	High Temperature Powder Coated T-304 Stainless Steel
Gasket Material	NovaMica HiTemp
Hardware Material	Stainless Steel
Optic Specifications	
Viewing Aperture Diameter	10.2 cm (4.0 in) Ø
Optic Material	Sapphire Crystal
Inspection Capabilities and Applications	
Shortwave IR; Midwave IR; Ultraviolet (UV); Visual Inspection; Gold Cup Inspection; High Temperature Applications	
Other	
Warranty	Limited Lifetime Warranty

*Caution: These dimensions are not installation dimensions. Do NOT cut prior to receiving your IRISS IR window and installation template. Specifications are subject to change without notice. For the most up-to-date specs, go to www.iriss.com

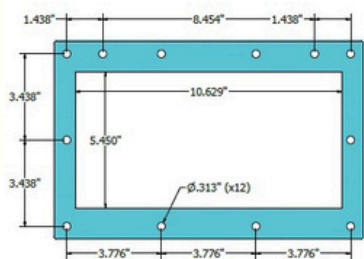
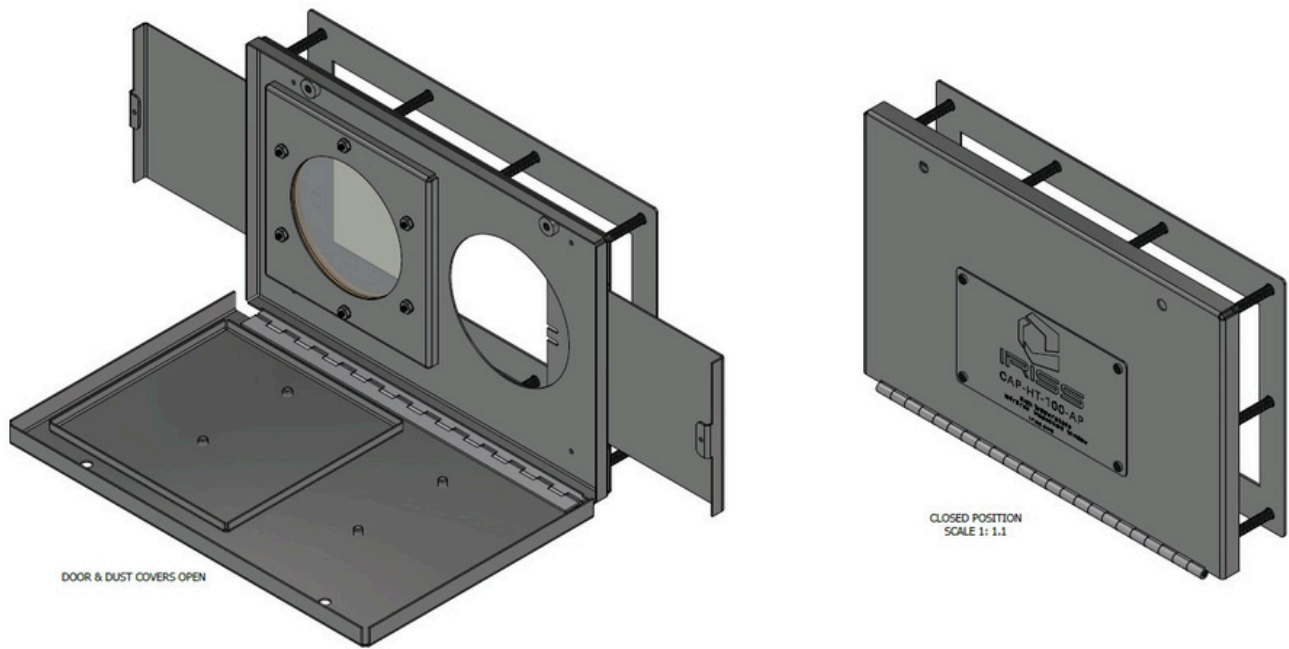

CUTOUT TEMPLATE (Opt.1)

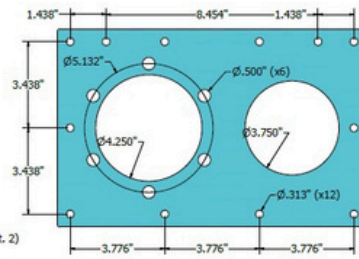

CUTOUT TEMPLATE (Opt.2)

Rev	By	Date	Approved	Date
 10088 Technology, Terrace Boulevard, Florida 34211 Phone: (941) 907-9128 Web: www.iriss.com Fax: (941) 907-9128 Email: info@iriss.com				
TITLE: High Temp IR Window with Access Port				
PART #: CAP-HT-100-AP-00-00				
WHOLE ASSEMBLY (Open)				
THICKNESS: 0.007"	MATERIAL: SS	Color: Black Texture (#100762)		
<input type="checkbox"/> DISCREET CONTROL <input type="checkbox"/> PRELIMINARY <input type="checkbox"/> RELEASE FOR FABRICATION CONTROL COPY				
ENGINEER	CUSTOMER	SK205	Full Scale	1: 1.1
DRAWN	BY	CHKD	BY	APPRD
10/25/2024	10/25/2024	10/25/2024	CAP-HT-100-AP	1

North America (HQ)
+1 (941) 907-9128

LATAM
+1 (941) 704-4445

EMEA
+44 (0) 843-507-0099

APAC
+1 (941) 704-4445

MENA
+974 399 24 0 24

India
+91 22 4969 0921



www.iriss.com

CAP-HT-100-AP Series Material Safety Data Sheet

MATERIAL SAFETY DATA SHEET – 11 SECTIONS

SECTION 1 - PRODUCT INFORMATION

Product Name	CAP-HT-100-AP Series Inspection Windows
Product Use	High Temperature Infrared Thermography and Gold Cup Inspection
Physical Mailing Address	10305 Technology Terrace, Bradenton, Florida 34211 USA
Emergency Contact	IRISS HQ, (941) 907-9128

SECTION 2 – COMPONENT PROPERTIES

Window Body	T-304 Stainless Steel, Non-reactive, Melting Point is Between 1400-1450°C
Window Hardware	Stainless Steel, Non-reactive, Melting Point is Between 1371-1399°C
Coating	ODAI Powder Coating HT003, Non-Reactive, No Combustible or Organic Components, 100% Silicon, Silicon Melting Point is 1414°C
Gasket	NovaMica HiTemp, Non-reactive, Melting Point is a Minimum of 1000°C
Lens	Sapphire Crystal, Non-reactive, Melting Point is Between 2030-2050°C

SECTION 3 – PHYSICAL DATA

Physical State	Solid, no Gases or Liquids Present
What Happens Under a Variety of Circumstances	This Product is Non-Reactive and Rated From -200-1000°C With no Adverse Changes
Flammability and How to Extinguish	This Product is Inflammable

SECTION 4 - HAZARDOUS INGREDIENTS

Ingredients	There Are no Hazardous Ingredients in This Product.
-------------	---

SECTION 5 – FIRE AND EXPLOSION DATA

Will it Ignite or Explode and How to Deal with it	This Product is Not Flammable or Explosive
How Stable is This Product	This Product Will Remain in its Exact State From -200-1000°C
How it Reacts Under Various Conditions	This Product is Non-Reactive

SECTION 6 – TOXICOLOGICAL PROPERTIES

Exposure Limits, In Summary, Immediate, and Long Term Effects to The Human Body	There Are no Toxic Parts Used in This Product
---	---

SECTION 7 – REACTIVITY DATA

Incompatibility With Other Substances	
Hazardous Decomposition Products	N/A
Information About How The Product Affects and Enters The Body	N/A

Personal Protective Equipment	Be cautious when interacting with this product as it will achieve the same temperature as the object that the window is installed upon when it reaches thermal equilibrium. Use an opening device or appropriately high temperature rated gloves when opening or closing the window.
-------------------------------	--

SECTION 9 – FIRST AID MEASURES

Information For Immediate First Aid Treatment	This product is nonhazardous, but if the installation environment causes the window to be hot and you are burned when interacting with it then seek the appropriate first aid treatment depending on the severity of the burn and contact a doctor or seek appropriate medical care.
---	--

SECTION 10 – NOTES

Notes	This product is intended to be used in applications where the maximum temperature of the installation surface is 1000°C. The process that is being monitored can be in excess of 1000°C, however the maximum recommended temperature of the surface the window will be affixed to is 1000°C.
-------	--

SECTION 11 – PREPARATION INFORMATION

Preparers Name	Joshua Robinson
Physical Mailing Address	10306 Technology Terrace, Bradenton, Florida 34211 USA
Contact Number	(941) 907-9128 ext. 2116

North America (HQ)
+1 (941) 907-9128

LATAM
+1 (941) 704-4445

EMEA
+44 (0) 843-507-0099

APAC
+1 (941) 704-4445

MENA
+974 399 24 0 24

India
+91 22 4969 0921



www.iriss.com