

IR lens, f=23 mm (24°) with case (for GF335, GF346)

P/N: T198267

Copyright

© 2020, FLIR Systems, Inc.

All rights reserved worldwide. Names and marks appearing herein are either registered trademarks or trademarks of FLIR Systems and/or its subsidiaries. All other trademarks, trade names or company names referenced herein are used for identification only and are the property of their respective owners.

Document identity

Publ. No.: T198267
 Commit: 64416
 Language: en-US
 Modified: 2020-03-11
 Formatted: 2020-03-11

Website

<http://www.flir.com>

Customer support

<http://support.flir.com>

Disclaimer

Specifications subject to change without further notice. Camera models and accessories subject to regional market considerations. License procedures may apply. Products described herein may be subject to US Export Regulations. Please refer to exportquestions@flir.com with any questions.



General description	
The standard 24° lens is suitable for the majority of applications.	
Licensing and classification	
License information	Interchangeable lens version of the FLIR GF3XX series requires US Department of State License and will be subject to limitations on resale, except inside US. Allow a minimum of 90 days after application submittal for approval.
Imaging and optical data	
Field of view (FOV)	24° × 18°
Minimum focus distance	0.3 m (1.0 ft.)
Focal length	23 mm (0.89 in.)
Lens identification	Automatic
F-number	1.5
Lens note	For spectral range 3–5 μm
Physical data	
Weight	0.30 kg (0.67 lb.)
Size (L × D)	57 × 80 mm (2.24 × 3.15 in.)
Shipping information	
List of contents	<ul style="list-style-type: none"> • Lens • Lens cap • Lens case
EAN-13	7332558009031
UPC-12	845188009571
Country of origin	Sweden

Compatible with the following products:

- 57501-0102; FLIR GF335 24°
- 59801-0101; FLIR GF346 14.5°
- 59801-0102; FLIR GF346 24°

**Camera with Lens IR f=23 mm (24°)
Camera with Lens IR f=38 mm (14,5°)**

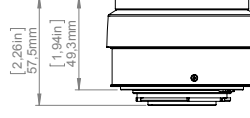
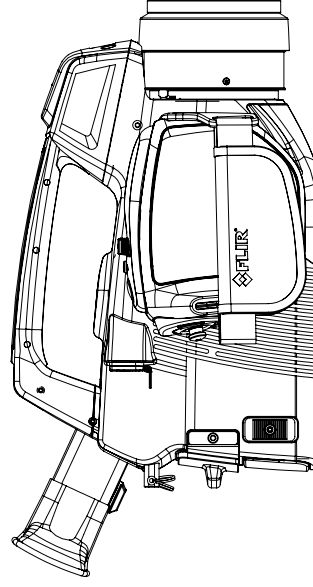
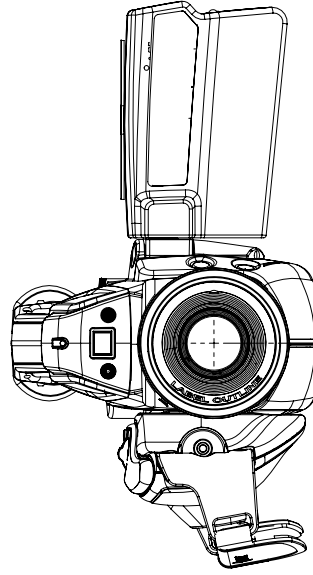
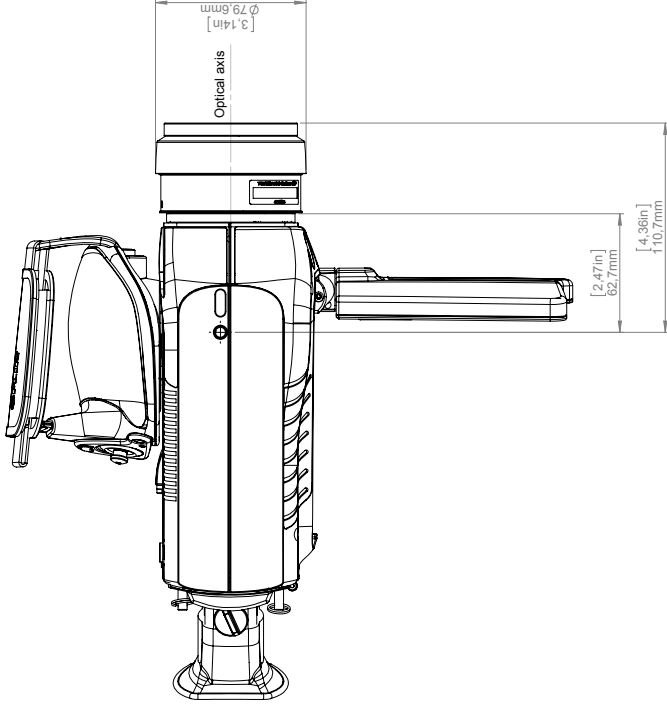

For additional dimensions see page 1

Modified	Drawn by	Size	
2013-02-18	R&D Thermography	A3	
Drawn by	Check	Scale	
2013-02-18		1:2	
Drawn by	Check	Drawing No.	Part No.
		T127603	Z(5)

Basic dimension FLIR GF3xx